

SS 163

1st Edition

JULY 1955

# ULTRA TWIN *De Luxe*

(R906)

WARNING: CHASSIS LIVE WHEN CONNECTED TO MAINS.

## GENERAL DESCRIPTION

The Ultra Twin de Luxe Receiver, Model R906, is a Superheterodyne receiver designed to operate either from self-contained batteries or mains.

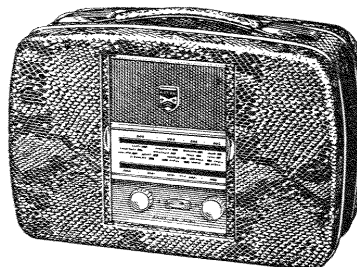

### Batteries.

L.T.—7.5 v	H.T.—85 v
Drydex H.1186 or Ever Ready AD.39	Drydex 529 or Ever Ready B.129

Mains: 200/250 Volts D.C./A.C., 25-100 cps.

### H.T. and L.T. Consumption.

		Mains.	Battery.
H.T.	... ..	85 v	85 v
		12.5 mA	12 mA
L.T.	... ..	6.5 v	7.5 v
		47.5 mA	53 mA

### Valves:

Frequency Changer	... ..	Mazda 1C2.
I.F. Amplifier	... ..	Mazda 1F3.
Detector, A.G.C. Rectifier and A.F. Amplifier	... ..	Mazda 1FD9.
Output	... ..	Mazda 1P11 or Brimar 3V4.

Equivalent valves may be fitted if the need arises.

Rectifier ... .. S.T.C. FAX1331A.

### Wave Bands:

M/W ... ..	190-550 metres.
L/W ... ..	1160-2000 metres.

Aerial: Self-contained Frame Aerial.

Intermediate Frequency: 471 Kc/s.

### Loudspeaker (756-97-1):

5-in. P.M. moving coil.  
Speech coil impedance: 3 ohms.  
Speech coil D.C. resistance: 2.6 ohms.

### Output Transformer (85115):

Ratio: 52:1.  
Primary D.C. resistance: 570 ohms approx.  
Secondary D.C. resistance: 0.5 ohms approx.

## CIRCUIT DESCRIPTION

### R.F. INPUT CIRCUIT:

**Medium Waves.**—Tuned frame aerial (L2), which is adjusted at the L.F. end by a small iron-cored loading coil (L1) and by trimmer "A" at the H.F. end.

**Long Waves.**—The medium wave frame is used in conjunction with a high Q loading coil (L3). This method gives improved selectivity and a reduction in static noise pick-up compared to a separate low Q long wave frame aerial. A fixed shunt capacitor (C1) is used to obtain the correct long wave coverage.

### OSCILLATOR CIRCUIT.

Tuned grid circuit with a conventional feed back winding couples Vg1 and Vg2 of the 1C2 pentagrid valve as the oscillator. On long waves the coupling between tuned and feed back winding is such that optimum heterodyne volts over the band are obtained, whilst on medium waves this condition is maintained by switching in circuit the shunt resistor R4. Medium wave tracking is three point, being adjusted at the L.F. end by L5 core and at the H.F. end by trimmer "B". Long wave tracking is single point centred at 210 Kc/s.

### I.F. STAGES.

Iron dust core tuned transformers, neutralised by C11.

### DIODE PENTODE AND OUTPUT.

The rectified signal is coupled to the grid of the pentode A.F. amplifier and is also fed via R6 to supply an A.G.C. voltage to grid of V1 and V2. Correct bias for V1 and V2 is obtained from the filament supply by the potentiometer R15, R8 and R9.

### POWER SUPPLY.

For mains operation a metal rectifier is used in a voltage compensated system, such that the H.T. and valve filament voltages remain sensibly constant on any mains voltage between 200 volts and 250 volts A.C. or D.C. The value of R22C has been chosen so that the rectifier efficiency is regulated to give the same D.C. voltage across C20B, whether the mains input voltage is D.C. or A.C. (of the same R.M.S. value).

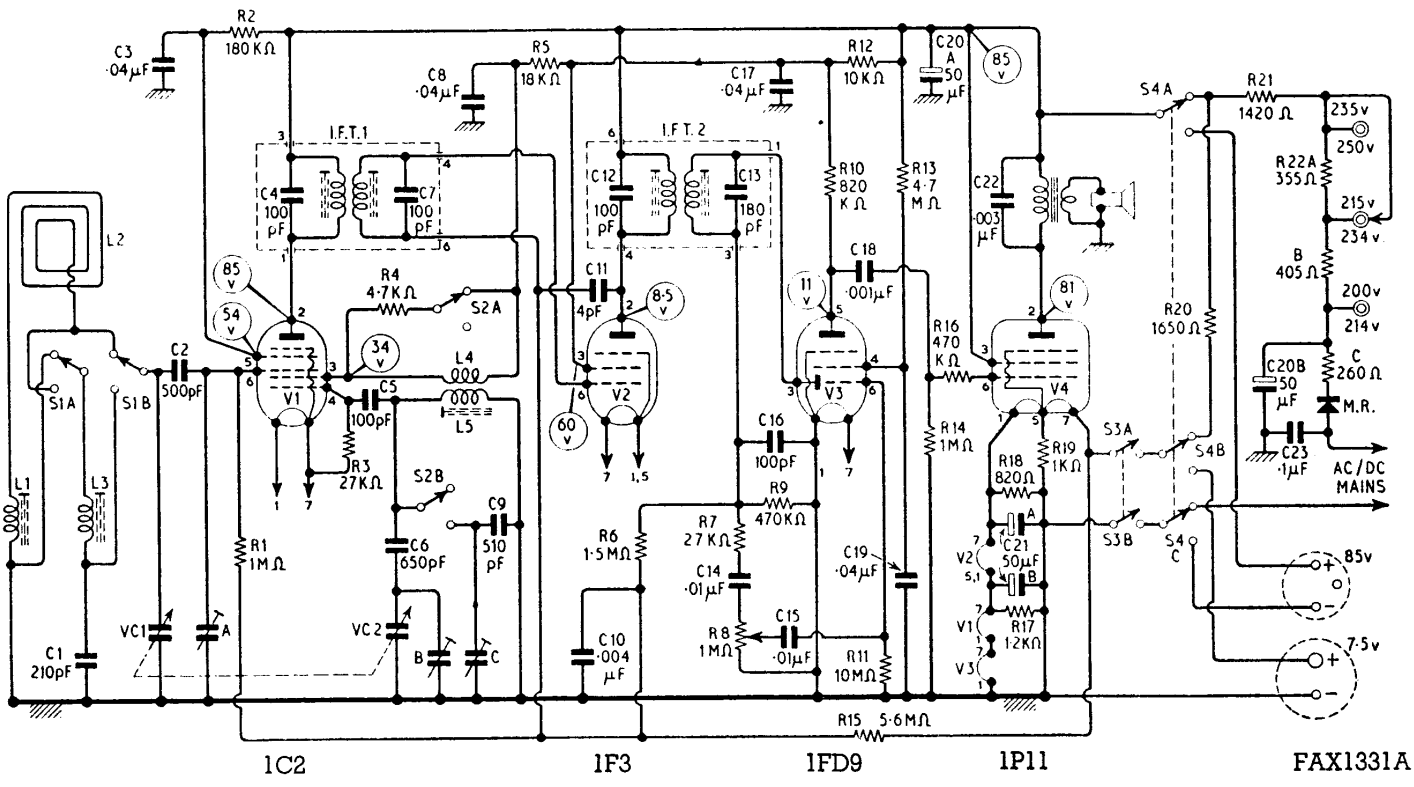

**CIRCUIT DIAGRAM**

Figures in circles refer to the voltages on the various electrodes. All voltages were taken with an Avo 7 meter on the highest permissible range.

Wave change switch shown in the medium wave position, mains/battery switch in mains position.

**CAPACITORS**

No.	Cap. pf.	Rating or Tol.
1	210	2%
2	500	20%
3	.04 mfd.	20%
4	100	2%
5	100	20%
6	650	2%
7	100	2%
8	.04 mfd.	20%
9	510	2%
10	.004 mfd.	20%
11	4	± 5
12	100	2%
13	180	2%
14	.01 mfd.	20%
15	.01 mfd.	20%
16	100	10%
17	.04 mfd.	20%
18	.001 mfd.	20%
19	.04 mfd.	20%
20 A/B	50 + 50 mfd.	350 v. EL
21 A/B	50 + 50 mfd.	12 v. EL
22	.003 mfd.	20%
23	.1 mfd.	300 v. A.C.
A	30	Tr.
B	60	Tr.
C	60	Tr.
VC1 & 2	520	2 Gang.

**WAVE CHANGE SWITCH CONNECTIONS**

Contact No.	To
1	Tr. C
2	C6, L5 tag g, C5
3	L4 tag h, C8, R5
4	R4
5	C1, L3 tag e
6	VC1, C2
7	Frame Aerial
8	L3 tag f
9	Chassis

**MAINS/BATTERY SWITCH CONNECTIONS**

Contact No.	To
12	L.T. Battery +
13	S 3A
14	R 20
15	H.T. Battery +
16	C20A
17	Junction R20/21
18	H.T. Battery -
19	S 3B
20	Mains Socket

**CONTINUITY TABLE**

L No.	Coil	Ohms approx
1	M/W Loading Coil } (214-63)	.8
3	L/W Loading Coil }	7.5
2	M/W Frame Aerial (352-38)	1.2
4	Osc. Coil, coupling }	1.1
5	Osc. Coil, tuning }	1.3

I.F.T.1 (852-106-1) I.F.T.2 (852-106-2)  
 Prim. 6.5 ohms 6.5 ohms  
 Sec. 6.5 " 4.5 "

Numbers in brackets after coils are part numbers and should be quoted with orders.

**RESISTORS**

No.	Ohms.	Watts or Current.
1	1 M	1/4
2	180 K	1/4
3	27 K	1/4 10%
4	4.7 K	1/4 10%
5	18 K	1/4 10%
6	1.5 M	1/4
7	27 K	1/4
8	1 M Pot.	1/4
9	470 K	1/4
10	820 K	1/4 10%
11	10 M	1/4
12	10 K	1/4 10%
13	4.7 M	1/4
14	1 M	1/4
15	5.6 M	1/4
16	470 K	1/4
17	1.2 K	1/4 10%
18	820	1/4 10%
19	1 K	1/4 10%
20	1650	47 mA. 1%
21	1420	58 mA. 1%
22A	355	58 mA. 5%
B	405	58 mA. 5%
C	260	130 mA. 5%

All tolerances 20% where not marked differently.

# UNDERSIDE VIEW OF CHASSIS

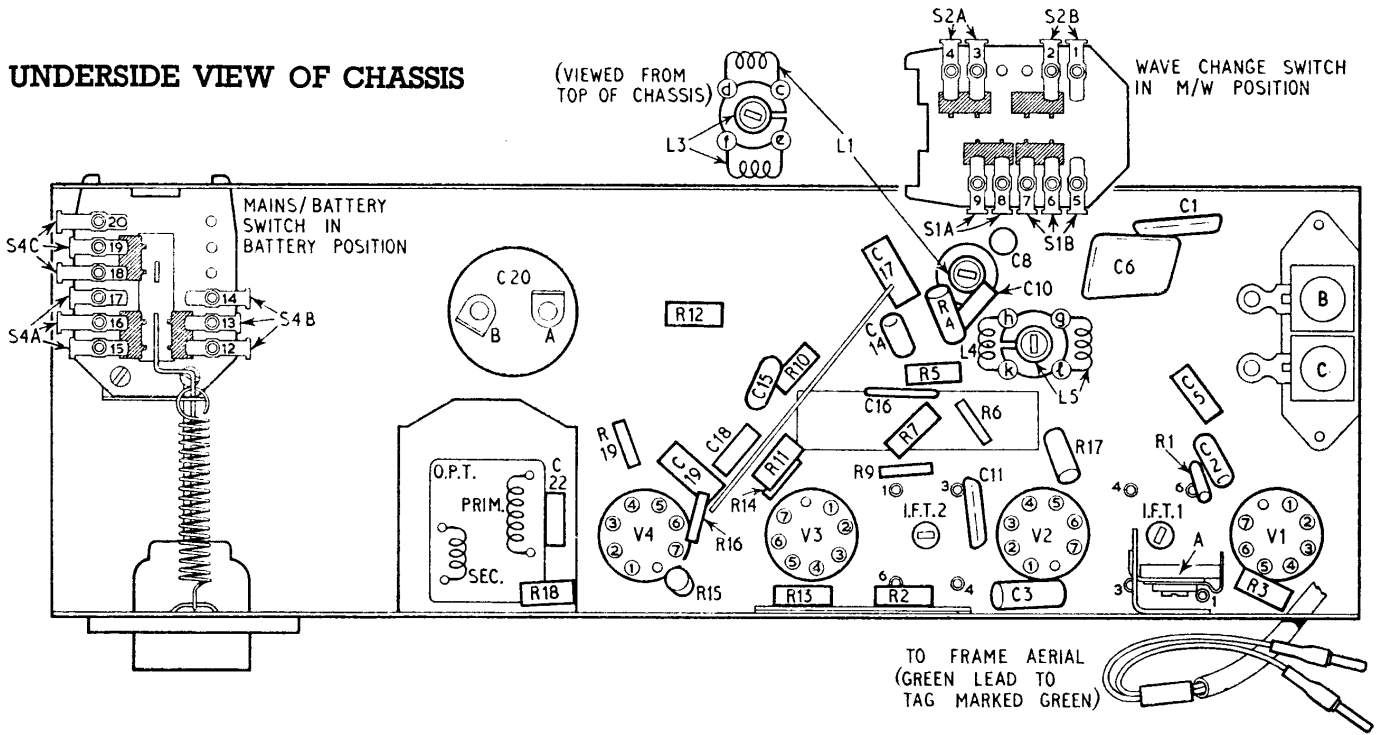

# TOP AND FRONT VIEW OF CHASSIS

Showing top of scale back plate and drive cord arrangement.

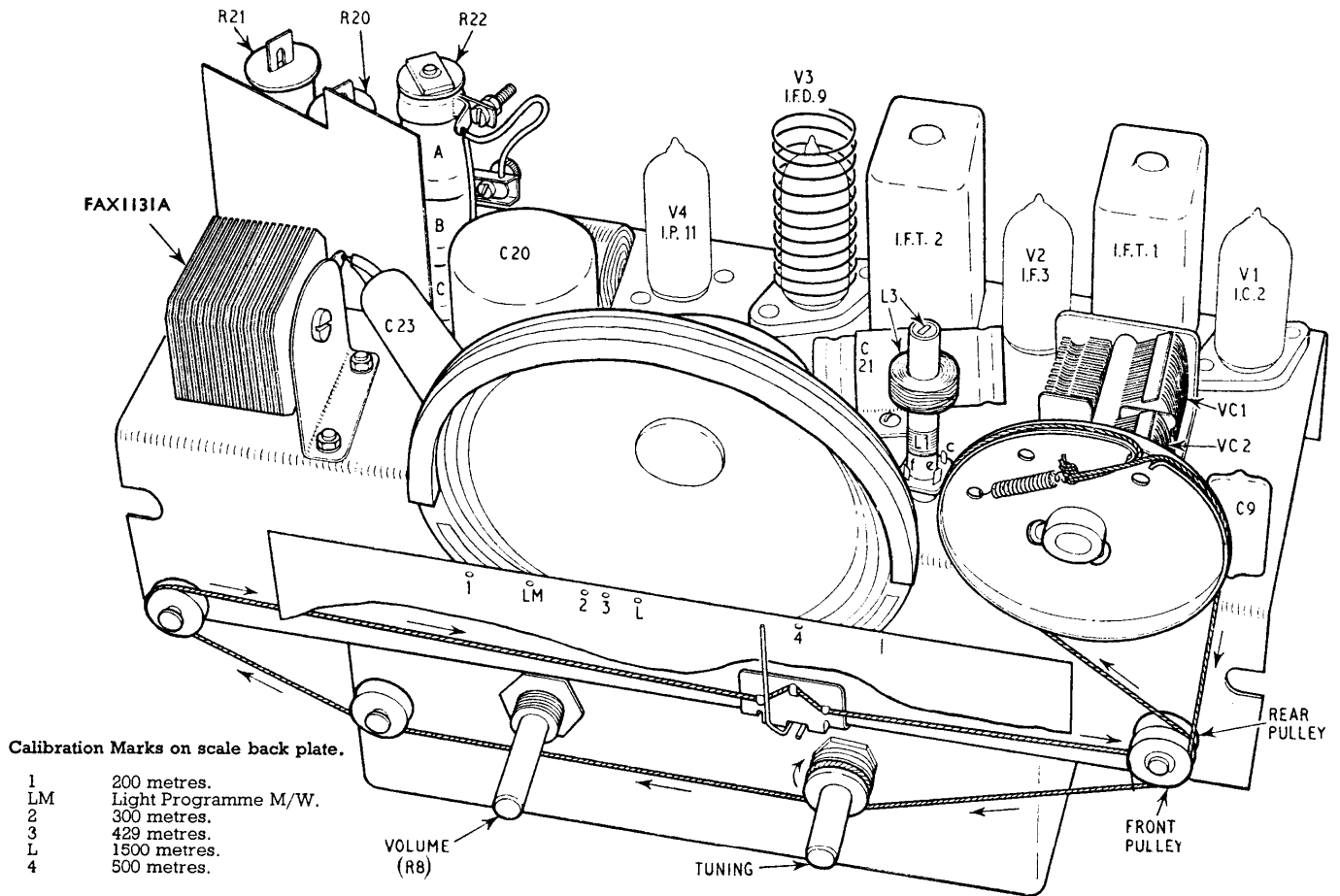

# ALIGNMENT PROCEDURE

**SIGNAL GENERATOR** covering medium wave and long wave ranges, modulated 30% at 400-1000 cps.

**OUTPUT METER** with a range showing a clear deflection at 0.5 volt if connected across the speech coil or 21 volts if connected across the primary of the output transformer.

**Note:** During alignment adjust signal generator output so that receiver output does not exceed the voltages given above.

For I.F. and R.F. alignment the output from the signal generator is fed directly into a transmitting coil which is placed about 6 ins. from the frame aerial. A suitable transmitting coil for alignment is approximately 14 turns of 18 S.W.G. En. Cu. wire wound on a  $\frac{7}{8}$  in. former to a length of  $1\frac{1}{2}$  in.

Two tuning points will be found when adjusting cores, the position nearest to the end of the former (chassis end on oscillator coil) being the correct one. A non-metallic trimmer tool must be used for the alignment of dust cores.

**CAUTION:** IT IS IMPORTANT TO PROTECT THE BATTERY PLUGS AGAINST CONTACT WITH ANY LIVE POINT.

## I.F. ALIGNMENT

The I.F. response curve is affected by coupling between the I.F. transformers and frame aerial. It is necessary therefore to position the chassis correctly with respect to the frame when carrying out I.F. alignment, and the following procedure should be followed:—

- (1) Remove chassis from cabinet.
- (2) Place cabinet face down and position chassis on cabinet back, (protected by a layer of thick paper) such that the mains socket corresponds with the appropriate hole in the cabinet back.
- (3) Lift open cabinet back (holding chassis in place), and insert mains plug; also feed aerial leads through aerial trimmer hole in cabinet back and connect leads in **reverse** polarity to frame aerial (i.e. red lead to green spot-tag).
- (4) Place transmitting coil inside cabinet and inject 471 Kc/s.
- (5) Switch receiver to Medium Waves, tune to 450 metres and adjust cores of 2nd and 1st I.F. transformers, in that order, for maximum symmetrical response.

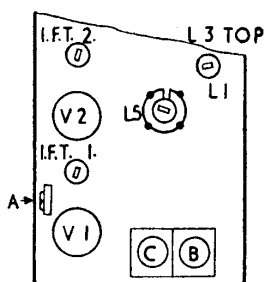

## R.F. ALIGNMENT

Operations 1-4 of the R.F. alignment table are carried out with the chassis in the same position as for I.F. alignment.

Operations 6 and 7 must be carried out with the chassis placed inside the cabinet, taking care to observe **correct polarity** of aerial lead connections. It is important that the **correct relative** position of the frame aerial, chassis and L.T. battery is maintained during alignment of core L1 and trimmer A.

Numbers in brackets next to the wavelengths in the table below refer to the calibration points on top of the scale back plate.

Signal Generator Frequency Kc/s.	Receiver Tuned to	Adjust for maximum.	
		Osc.	Aerial.
1. 600	M/W 500 m. (4)	Core L5	
2. 1,500	200 m. (1)	Trimmer B	
3.	Repeat operations 1 and 2.		
4. 210	L/W 1,429 m. (3)	Trimmer C	Core L3
5.	Replace chassis in cabinet, insert L.T. battery <b>only</b> . Stand cabinet on side (hinge at bottom), and insert non-metallic trimming tool through hole in cabinet bottom to engage with core L1. Check aerial leads are correctly connected, and close back. (See note.)		
6. 600	M/W 500 m. (4)	—	Core L1
7. 1,500	200 m. (1)	—	Trimmer A
8.	Repeat operations 6 and 7.		

After any adjustment to the M/W oscillator trimmer or core, the L/W trimmer (C) must also be realigned.

**NOTE:** The presence of the batteries affects the frame aerial, and the alignment procedure is normally carried out with the L.T. battery in position, which gives the best compromise performance on mains with or without batteries.

If the receiver is only to be operated without batteries, a slight increase in sensitivity can be obtained by aligning without them.

## REMOVAL OF CHASSIS

Withdraw the mains plug from its socket and pull open back, using the two holes provided on the right-hand side. Remove batteries and the fibre isolating piece protecting the battery plugs from contact with the chassis. Pull off the front knobs and the wave-change knob and withdraw the frame aerial leads from the sockets on the frame aerial. Unscrew two PK screws on the back of the chassis and withdraw chassis.

**Note:** The frame aerial is contained in an envelope, attached to the back by means of four eyelet rivets. Should the need arise for replacing the frame aerial drill out eyelet rivets with care. A replacement will be supplied complete in the envelope and with four special screws for re-fitting the envelope and finger guard strip.

## ENGLAND and WALES

Telephone: PRIMrose 8111/6  
 Telegraph: Ultrserv, Norphone, London.  
 or Write: ULTRA SERVICE,  
 Erskine Road, Chalk Farm,  
 London, N.W.3

# ULTRA SERVICE

**For All Service Enquiries**

RADIO TECHNICAL ADVICE BUREAU.  
 RADIO SERVICE — SERVICE SHEETS — RADIO SPARES

## SCOTLAND

Telephone: Central 6142/3 (Glasgow)  
 or Write: ULTRA SERVICE,  
 40, Wellington Street,  
 Glasgow, C.2