

"TRADER" SERVICE SHEET  
1002

# BUSH DAC10

Press-button Superhet



845-2,070 m. In early versions the three pre-set stations were all for M.W. operation, but in later versions one of them covered the L.W. band.

Release date and original price: January, 1950; £14 10s, reduced later to £13 19s 8d. Purchase tax extra.

## CIRCUIT DESCRIPTION

All the switches associated with the press-button unit have been coded so as to indicate their action when a button is pressed. Thus a switch with the suffix **a, b, c** or **d** closes when its button is pressed, while one labelled **x** or **z** opens. When the button is released these actions are reversed. Each button operates two sets of switches, one in the aerial circuit and one in the oscillator circuit. All the switches in both groups operated by a given button bear the same number, the individual switches being identified by their suffixes.

Frame aerial coils **L1** (L.W.) or **L2** (M.W.) are tuned manually by **C33** via

**S1b** (M.W.) or **S1x, S2d** (L.W.); or automatically by pre-set capacitors **C28** (L.W.) or **C29, C30** (M.W.). **S2b** closes with **S2a** to connect the trimmer **C31**. When the M.W. button is pressed **S1a** closes to short-circuit the L.W. winding **L1**.

When the M.W. button is released, **S1x** closes to connect **V1** hexode control grid and the frame winding to the other circuits. When any M.W. pre-set button is pressed its **a** switch connects the tuning capacitors, and its **a** and **b** switches together short-circuit **L1**.

First valve (**V1**, Mullard UCH42) is a triode hexode operating as frequency changer with internal coupling. For manual tuning, oscillator grid coils **L6** (M.W.) and **L7** (L.W.) are tuned by **C34**. Parallel trimming by **C10, C35** (M.W.) and **C12, C36** (L.W.); series tracking by **C11** (M.W.) and **C7** (L.W.). Reaction coupling from anode via **L8** (M.W.) and **L9** (L.W.).

For automatic or pre-set tuning, pre-set coils **L3** or **L4** (M.W.) or **L5** (L.W.), are connected via their **d** switches across the L.W. tuning coil **L7**, which with **L9** then acts as a master oscillator circuit.

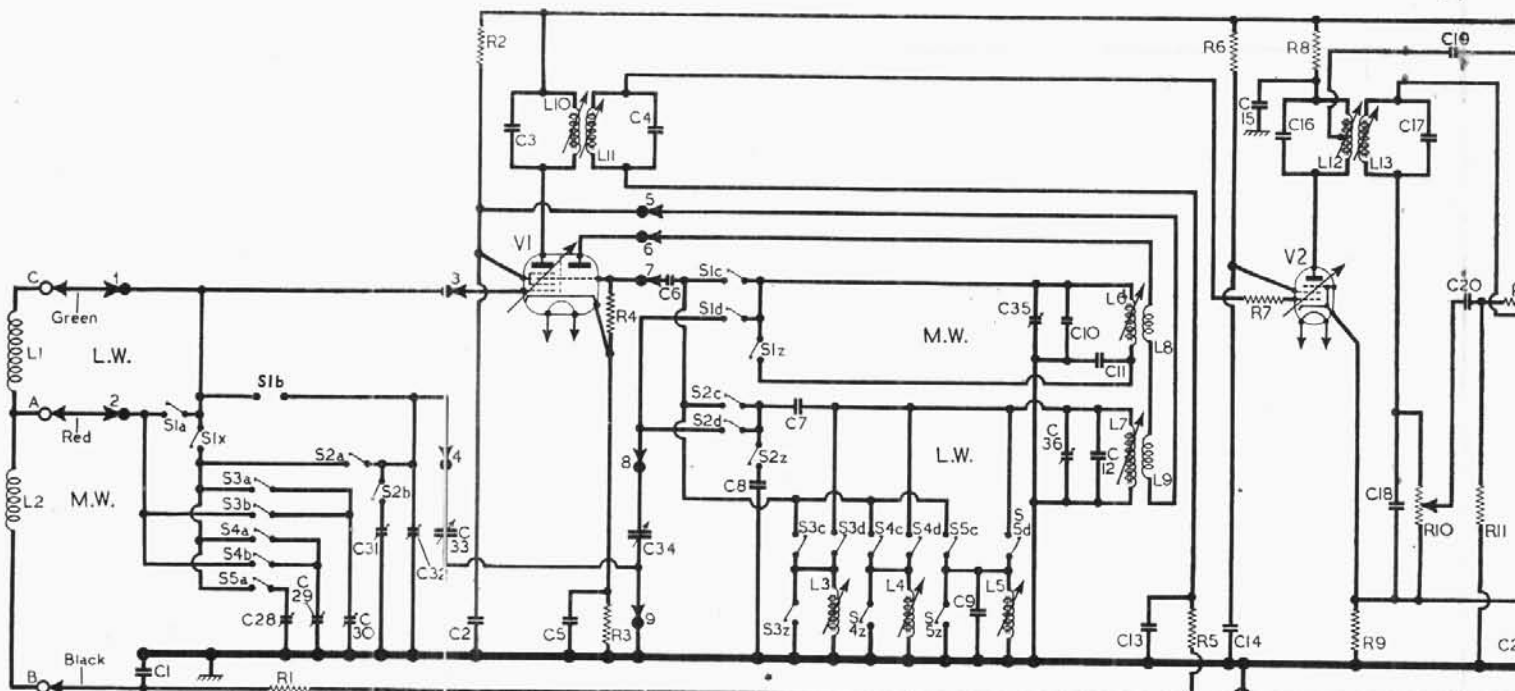

Circuit diagram of the Bush DAC10 A.C./D.C. superhet. No provision is made for the connection of an external aerial. The frame aerial connections are lettered **A, B** and **C**, and the connections between the chassis and the tuning unit are numbered **1** to **9**. Note that M.W. is the lower coil in the aerial circuit, and the upper coil in the oscillator.

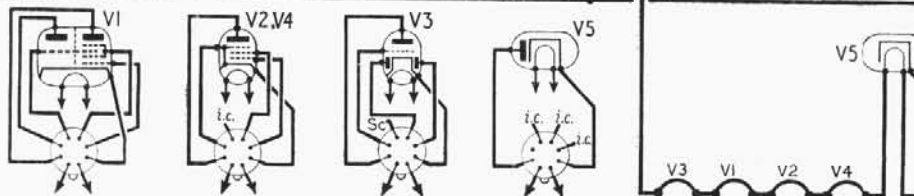

As S22 is closed the L.W. manual button is not depressed, C7 and C8 in series are shunted across the tuning circuit during auto-tuning.

Second valve (V2, Mullard UF41) is a variable-mu R.F. pentode operating as intermediate frequency amplifier with tuned transformer couplings C3, L10, L11, C4 and C16, L12, L13, C17.

#### Intermediate frequency 465 kc/s.

Diode signal detector is part of double diode triode valve (V3, Mullard UBC41). Audio frequency component in rectified output is developed across volume control R10, which acts as diode load, and is passed via C20 to grid of triode section. I.F. filtering by C18 and C22.

Second diode of V3, fed via C19 from V2 anode, provides D.C. potential which is developed across load resistor R14 and fed back as bias to F.C. and I.F. stages, giving automatic gain control.

Resistance-capacitance coupling by R13, C23 and R15 between V3 anode and pentode output valve (V4, Mullard UL41). Tone correction in V4 anode circuit by C24, and in the cathode circuit by negative feed-back developed across R17.

H.T. current is supplied by I.H.C. rectifying valve (V5, Mullard UY41). Smoothing by electrolytic capacitors C25, C26 and resistor R20. Valve heaters, together with ballast resistor R19 and scale lamps, are connected in series across the mains input. R18 limits the rectifier surge current, and the scale lamps are shunted by R21.

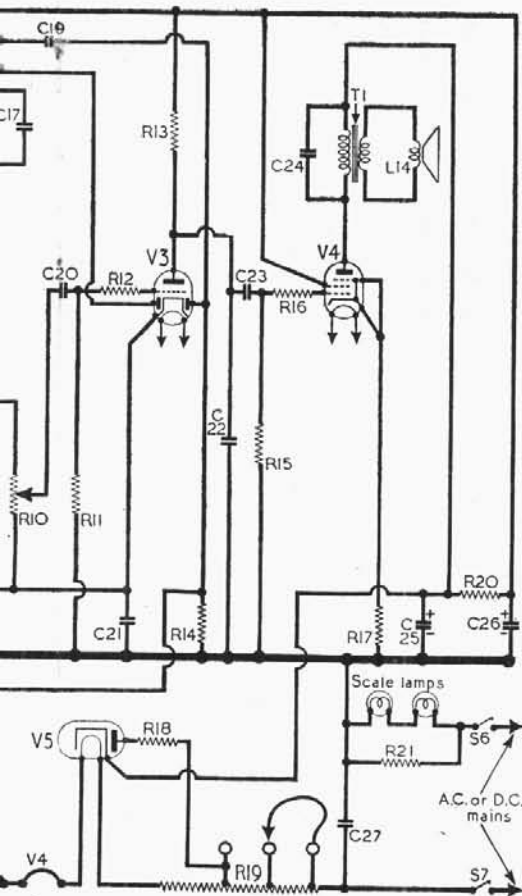

RESISTORS		Values	Locations
R1	A.G.C. decoupling	1MΩ	E4
R2	V1 H.T. feed ...	15kΩ	G4
R3	V1 G.B. ...	220Ω	G4
R4	V1 osc. C.G. ...	47kΩ	G4
R5	A.G.C. decoupling	1MΩ	E4
R6	V2 S.G. feed ...	47kΩ	F4
R7	V2 C.G. stopper ...	220Ω	F4
R8	V2 H.T. decoup. ...	10kΩ	F4
R9	V2 G.B. ...	330Ω	F4
R10	Volume control ...	500kΩ	D4
R11	V3 C.G. ...	2.2MΩ	D4
R12	V3 C.G. stopper ...	100kΩ	E4
R13	V3 anode load ...	150kΩ	D4
R14	A.G.C. diode load ...	1MΩ	E4
R15	V4 C.G. ...	470kΩ	E4
R16	V4 C.G. stopper ...	47kΩ	D4
R17	V4 G.B. ...	150Ω	D4
R18	V5 surge limiter ...	250Ω	C1
R19	Ballast resistor ...	1.25kΩ†	C1
R20	H.T. smoothing ...	10kΩ	D4
R21	Scale lamp shunt...	250Ω	B1

† Tapped at 950Ω + 150Ω + 150Ω from V5 heater.

OTHER COMPONENTS		Approx. Values (ohms)	Locations
L1	Frame aerial coils	4-25	A1
L2		3-0	A1
L3		2-0	F4
L4	Oscillator pre-set tuning coils ...	2-0	E4
L5		4-5	E4
L6	Oscillator tuning coils ...	3-0	F4
L7		4-0	F4
L8	Oscillator reaction coils ...	0-5	F4
L9		1-0	F4
L10	1st I.F. trans. { Pri. Sec. }	12-5	B2
L11		12-5	B2
L12	2nd I.F. trans. { Pri. Sec. }	12-5	B2
L13		12-5	B2
L14	Speech coil ...	3-0	—
T1	{ Primary ... Secondary ... }	570-0	—
S1-S5	Waveband switches	—	F3
S6, S7	Mains sw., g'd R10	—	D4

If the component numbers given in the above tables are used when ordering replacement parts, dealers are advised to mention the fact on the order, as these numbers may differ from those used in the manufacturers' diagram.

#### VALVE ANALYSIS

Valve voltages and currents given in the table below are those derived from the manufacturer's information and were taken when the receiver was operating from 230 V A.C. mains. The receiver was switched to M.W., and the volume control set to maximum, but there was no signal input.

Voltages were measured on a model 7 Avometer, using the 1,000 V range for H.T. voltages but the 10 V range for cathode bias voltages. The negative lead was connected to chassis.

Valves	Anode		Screen		Cath.
	V	mA	V	mA	V
V1 UCH42	{ 98 47 }	{ 1.5 0.5 }	47	—	—
V2 UF41	74	2.5	57	0.8	0.8
V3 UBC41	74	0.2	—	—	1.3
V4 UL41	190	27.5	98	4.0	5.0
V5 UY41	†220	—	—	—	205.0

† A.C. volts.

CAPACITORS		Values	Locations
C1	A.G.C. decoupling	0.05μF	F4
C2	V1 S.G. decoup. ...	0.05μF	G4
C3	1st I.F. trans. tuning ...	110pF	B2
C4		110pF	B2
C5	V1 cath. by-pass ...	0.05μF	G4
C6	V1 osc. C.G. ...	50pF	G4
C7	L.W. tracker ...	390pF	F4
C8	Pre-set osc. trim...	200pF	G3
C9	Pre-set osc. trim...	340pF	D3
C10	M.W. osc. trim. ...	33pF	G3
C11	M.W. osc. tracker	605pF	G3
C12	L.W. osc. trim. ...	200pF	D3
C13	A.G.C. decoupling	0.05μF	F4
C14	V2 S.G. decoup. ...	0.05μF	F4
C15	V2 anode decoup.	0.95μF	F4
C16	2nd I.F. trans. tuning ...	110pF	B2
C17		110pF	B2
C18	I.F. filter ...	100pF	E4
C19	A.G.C. feed ...	50pF	E4
C20	A.F. coupling ...	0.01μF	D4
C21	V2, V3 cath. by-pass	0.05μF	F4
C22	I.F. filter ...	0.004μF	E4
C23	A.F. coupling ...	0.01μF	E4
C24	Tone corrector ...	0.01μF	—
C25*	H.T. smoothing	32μF	B1
C26*		16μF	B1
C27	R.F. filter ...	0.1μF	D3
C28†	Pre-set aerial tuning	450pF	E3
C29†		450pF	E3
C30†		150pF	E3
C31†	L.W. aerial trim...	40pF	F3
C32†	M.W. aerial trim.	40pF	F3
C33†	Aerial tuning ...	528pF	A1
C34†	Oscillator tuning	528pF	B1
C35†	M.W. osc. trimmer	—	F4
C36†	L.W. osc. trimmer	—	F4

\* Electrolyte. † Variable. ‡ Pre-set.

#### DISMANTLING THE SET

**Removing Chassis.**—Remove cabinet back cover, held by four 4BA bolts recessed into the corners of the back cover; remove press-button and tuning scale escutcheon, held by four 4BA instrument headed bolts;

lay receiver face downwards on the bench and remove the two 4BA chassis fixing bolts (with washers and spacers) from the chassis brackets immediately below the control spindles; withdraw chassis to extent of speaker leads and disconnect them from the screw terminals on the output transformer.

When replacing, check that the locating pegs in the front of the cabinet engage in the grommets on the front side of the chassis.

**Removing Tuning Unit.**—Unsolder from the various points indicated in our circuit diagram and our sketch of the tuning unit the nine leads numbered 1-9 connecting the unit to the chassis; remove the press-button knobs (pull-off); remove the 4BA bolts (with lock-washers and spacing collars) holding the ends of the press-button switch unit and the diagonal cross-brace members to the underside of the chassis deck; slacken the two 4BA bolts holding the cross-braces to the side chassis members, and swivel the braces out of the way;

remove from the chassis deck the 6BA screw (with washer), situated at the side of the electrolytic unit C25, C26, which holds a long hexagonal pillar supporting the bottom of the tuning unit, when the unit can be withdrawn from the chassis.

When replacing, the unit should be (Continued col. 1 overleaf)

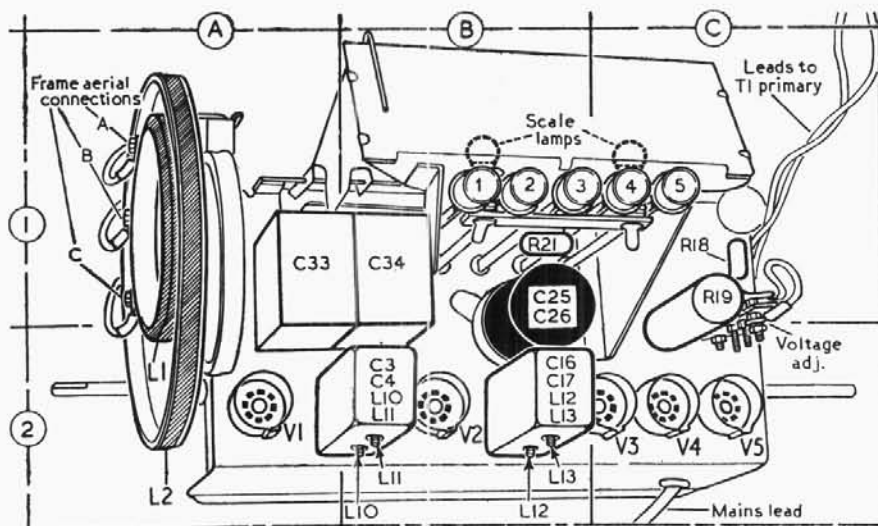

Plan view of the chassis. The press-buttons are numbered 1 to 5 to agree with the switch group numbers in our circuit diagram, and with the switch diagram below. The scale lamps pass through the press-button plungers.

#### Dismantling the set—continued

located as shown in our underside view of the chassis. Insert the two 4BA screws through the chassis deck and through the holes in the press-button switch unit, then add the spacing washer, then the end of the diagonal cross-brace, and finally the lock-washers and nuts. This operation may be facilitated by freeing the cross-braces entirely from the side-members instead of swivelling them.

#### DRIVE CORD REPLACEMENT

Two separate cords of nylon braided glass yarn are used for the tuning drive. The main drive to the gang requires about 2 feet of cord, and the cursor drive about

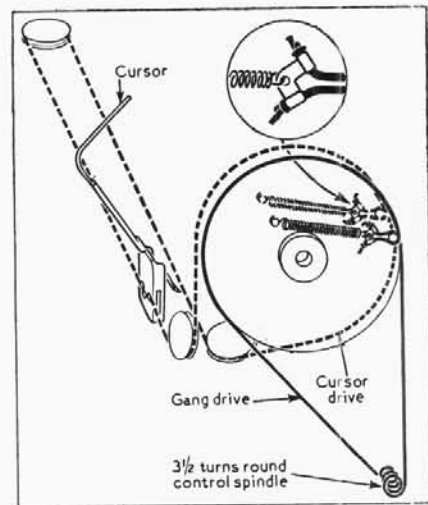

Sketch of the tuning drive system, which employs separate cords for gang drive and cursor drive. It is drawn as seen when viewed from the front right-hand corner of the chassis. Inset is shown the method of fixing the cord to the anchor plates.

3 feet. These lengths leave sufficient spare cord for tying off.

Two grooves are provided in the moulded drive drum for the two cords, and they do not cross. The cursor drive cord occupies the inner groove (nearer the chassis), and the gang drive the outer groove. If both cords are being replaced,

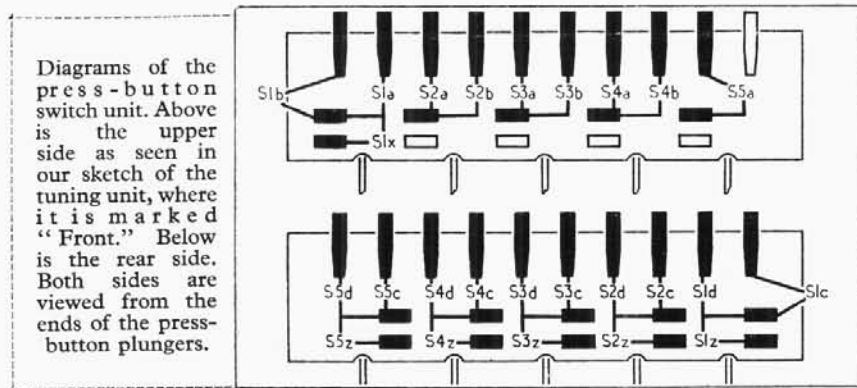

Diagrams of the press-button switch unit. Above is the upper side as seen in our sketch of the tuning unit, where it is marked "Front." Below is the rear side. Both sides are viewed from the ends of the press-button plungers.

the cursor drive should be fitted first. The makers recommend removing the gang drive, if it is in position, before fitting the cursor drive.

The ends of the cords are tied to anchor plates as shown inset in our sketch of the system. The sketch is drawn as seen from the front right-hand corner of the chassis, with the gang at maximum capacitance. To reach the drive drum, the frame aerial assembly must be dismantled (one screw with washer). When replacing it, a locating lug near the screw fits into a hole in the plastic aerial support.

The cursor can be attached to the cord after the latter is fitted. The cord slips into three staggered claws, which hold it firmly. It should be fitted while the gang is at maximum capacitance, and so positioned on the cord that the pointer below the cursor is approximately opposite the "Max" mark on the substitute scale. Final adjustment can then be made by

turning the drive drum on the gang spindle, after slackening the two fixing screws in its centre boss.

Spare cords and anchor plates for the gang drive (part No. AS 17038) and cursor drive (part No. AS 17037), and tension springs (part No. P1941) can be obtained from the makers' Service Department, Bush Radio, Ltd., Power Road, Chiswick, London, W.4.

#### GENERAL NOTES

**Switches.**—All the switches concerned with the tuning circuits are embodied in a press-button unit using five buttons. Viewing these buttons from the rear of the set, and numbering them from left to right, their functions are: 1, M.W. manual tuning; 2, L.W. manual tuning; 3, M.W. pre-set station, 200-350 m; 4, M.W. pre-set station, 325-550 m; 5, L.W. pre-set station, 1,100-1,875 m. (See also under "Chassis Modifications").

The switches are all numbered according to their control button. All S1 switches, for instance, are those in the aerial and oscillator circuit which are controlled by the M.W. manual button, and so on, using the foregoing numbers for each button. The action of the switches is explained at the beginning of "Circuit Description".

The switch unit is mounted on the tuning unit, which carries all the components concerned with R.F. and oscillator tuning with the exception of the gang. Its position is indicated in our sketch of the

tuning unit in col. 4, and diagrams of the two sides of the unit appear above, where the switches are identified.

S6, S7 are the Q.M.B. double-pole mains switches, ganged with the volume control R10.

**Scale Lamps.**—These are two Osram lamps, with small clear spherical bulbs and M.E.S. bases, rated at 3.5 V, 0.15 A. Access is gained to them by removing the back cover and unscrewing the two nuts (with lock-washers) by which the panel on which they are mounted is held to the scale assembly, when they can be withdrawn, together with their shunt resistor R21.

**Ballast Resistors.**—The mains voltage adjustment resistor R19 is a wire-wound cement-coated unit rated at 15 W. The scale lamp shunt resistor R21 is a wire-wound coated unit rated at 7 W.

**Resistors R18, R20.**—The surge limiter R18 is a wire-wound coated unit rated at



4 W. The H.T. smoothing resistor **R20** is a carbon type unit rated at 2 W.

**Chassis Modifications.**—In early models, **R18** was 150Ω, 1 W, **C8** was 220pF, and **C10** was 30 pF. The introduction of a L.W. press-button, too, was made during production. Previously the three pre-set stations were all M.W. The ranges of press-buttons 3 and 5, numbering from left to right when viewed from the rear, were the same as buttons 3 and 4 in our sample. Button 4 then covered a range of 250-400 m.

### CIRCUIT ALIGNMENT

**I.F. Stages.**—These may be adjusted without removing the chassis from its cabinet. Switch set to M.W., tune to approximately 300 m and unscrew the cores fully of coils **L13**, **L12**, **L11** and **L10** (location reference B2). Connect the output of the signal generator to control grid (pin 6) of **V2** and chassis, feed in a 465 kc/s (645.16 m) signal and adjust the cores of **L13** and **L12**, in that order, for maximum output. Transfer "live" signal generator lead to control grid (pin 6) of **V1** and adjust the cores of **L11** and **L10** in that order for maximum output. Do not re-adjust the cores of **L13**, **L12**. Reduce the input as the circuits come into line to avoid A.G.C. action.

**R.F. and Oscillator Stages.**—Remove chassis from cabinet and feed the output of the signal generator into a single loop of wire approximately 10in by 8in, placed about 12in to 18in away from the frame aerials and parallel to them. A sensitive output meter should be used as a visual indicator.

As the tuning scale remains fixed in the cabinet when the chassis is removed, reference must be made to the substitute tuning scale printed on the chassis flange just above the press-button unit. Check that with the gang at maximum capacitance, the pointer on the bottom of the cursor carriage coincides with the "Max." mark on the substitute tuning scale.

**M.W.**—Switch set to M.W., tune to 0.6 on the substitute scale, feed in a 500 m (600 kc/s) signal and adjust the core of **L6** (F4) for maximum output. Tune set to 1.5 on substitute scale, feed in a 200 m (1,500kc/s) signal and adjust **C35** (F4) and **C32** (F3) for maximum output. Check calibration at 500 m, and repeat the foregoing adjustments if necessary.

**L.W.**—Switch set to L.W., tune to 0.15 on substitute scale, feed in an 1,800 m (150 kc/s) signal and adjust the core of **L7** (F4) for maximum output. Tune set

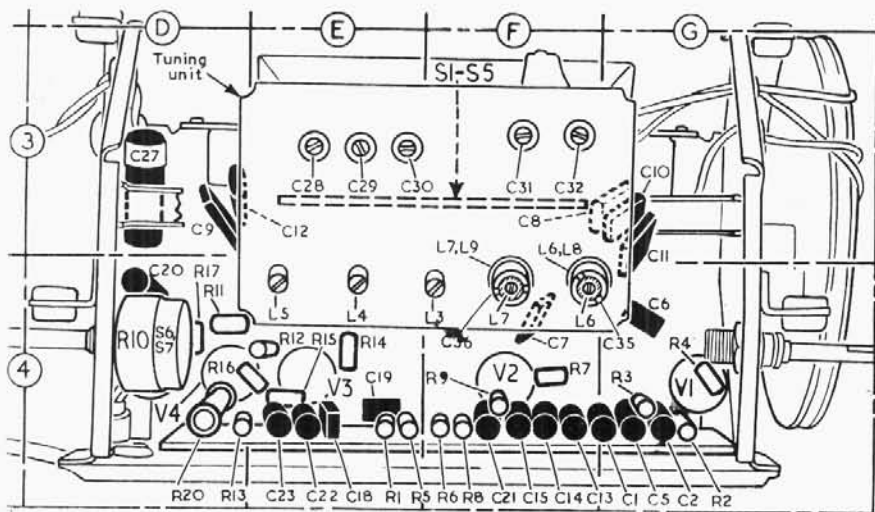

Underside drawing of the chassis, with the tuning unit in position. All the R.F. and oscillator alignment adjustments are indicated here. A separate drawing of the tuning unit after removal appears at the foot of this page.

to 0.3 on substitute scale, feed in a 1,000 m (300 kc/s) signal and adjust **C36** (F4) and **C31** (F3) for maximum output. Check calibration at 1,800 m, and repeat the foregoing adjustments if necessary.

### Pre-set Stations

A signal generator may be used to set these adjustments roughly, but they should be subsequently adjusted on the stations they are intended to receive.

Numbering from right to left (looking at front of chassis) the press-buttons are: 1, M.W. manual; 2, L.W. manual; 3, 200-350 m pre-set; 4, 325-550 m pre-set; 5, 1,100-1,875 m pre-set.

The adjustments for press-buttons 3, 4 and 5 are as follows: 3, **L3** (F4), **C30** (E3); 4, **L4** (E4), **C29** (E3); 5, **L5** (E4), **C28** (E3). The receiver should be allowed to warm up for fifteen minutes at the user's house before final adjustments are made.

**Note.**—Adjustment of the L.W. oscillator circuit **L7** will affect the tuning of the pre-set stations, so the cores of **L3**, **L4** and **L5** should be reset after any readjustment of **L7**.

## Radio Service Hints

### Philco B2806

The symptom is a squealing oscillation when operating the volume control near maximum volume. Strangely enough we found it on two receivers that had been sold and in use for a few weeks before the complaint was made.

On checking through we found that the connecting wire from the loudspeaker transformer primary passed through the chassis, through the pin connections of the 12Q7 valve (**V3** in *Trader Service Sheet* 961), under the grid resistor **R7**, over the top of the locating key, and so to the anode pin of **V4**.

By unsoldering the wire from the anode pin, withdrawing the wire and then taking it directly from the hole in the chassis to the anode pin of **V4**, the trouble is cured.—S. S. D., Patricroft.

### Sobell 516 A.C.

One of these receivers came in for service crackling very loudly on all three wavebands, while tone and volume seemed very much below normal.

We first checked the grid capacitor to the 6V6 output valve, but this was O.K., and after isolating each subsequent suspect without result we eventually traced the trouble to the waveband switch.

The end wafer breaks the H.T. feed to the screens of the frequency changer and the I.F. amplifier on gram to prevent radio break-through, but as a result probably of dust and grease on the wafer, a semi-conducting layer had formed which permitted H.T. leaks spasmodically to the grid of the A.F. valve.

We removed the H.T. feed from the switch and took it directly to the screens of the valves concerned. This meant that the F.C. and I.F. valves were still operating on gram, but break-through was not troublesome in our case.—G. R. W., Liverpool.

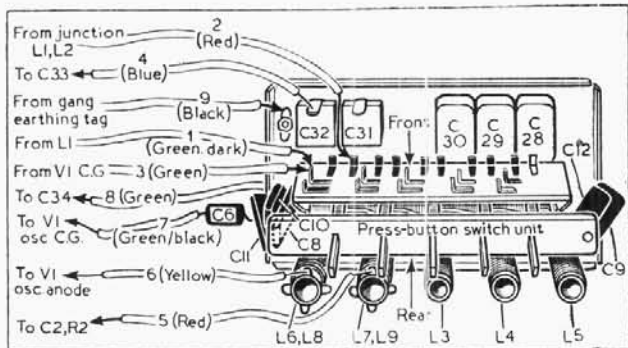

Sketch of the tuning unit after removal from the chassis. All the connecting leads (numbered 1 to 9) between the unit and the chassis are identified here. An arrow-head indicates the end of the lead that is unsoldering in our dismantling instructions.